

CROWN

Specifications

**WE 2300 Series
WS 2300 Series**

Walkie Stackers

WE/WS 2300

Series



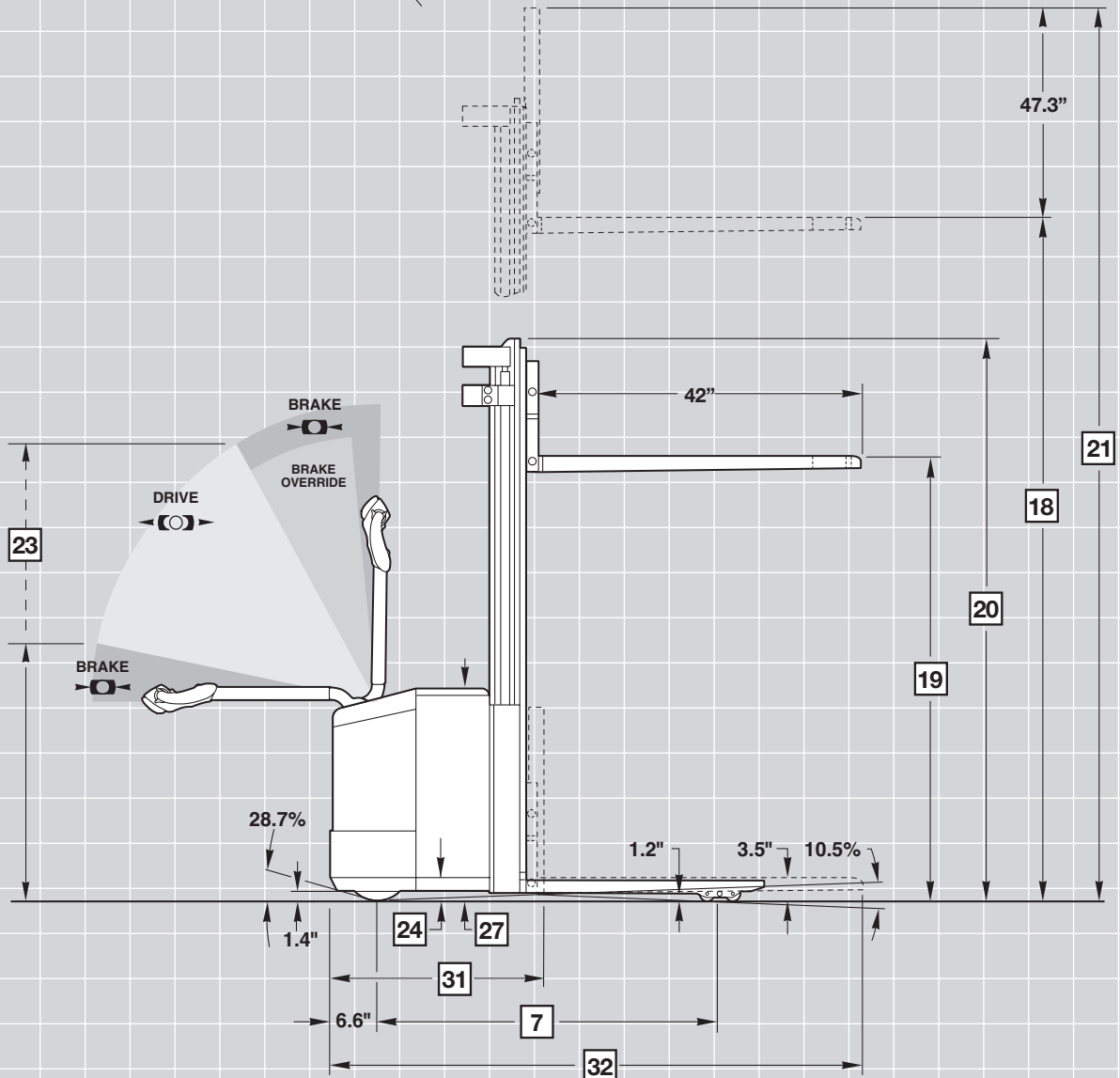
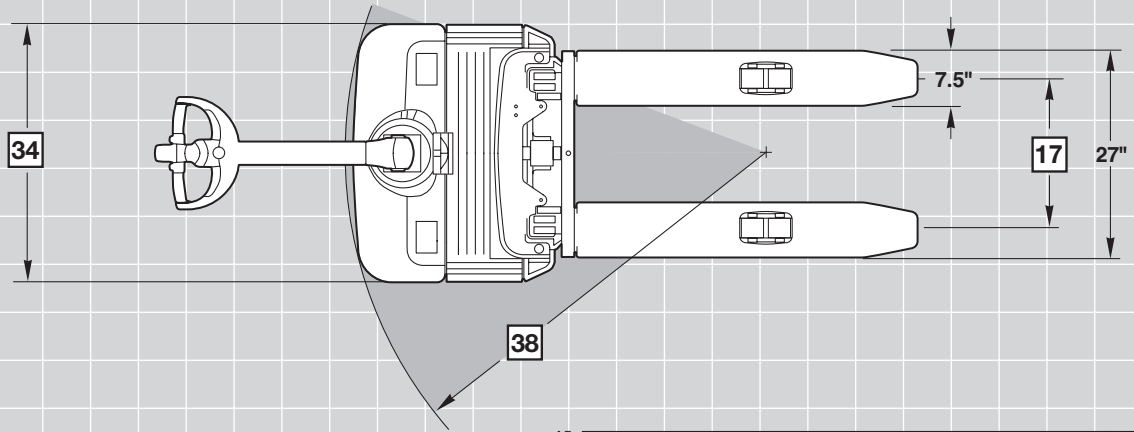

General Information	1	Manufacturer		Crown Equipment Corporation		
	2	Model		WE 2300-25	WE 2300-30	
		Mast Type		TL	TF	
	3	Power		Electric		
	4	Operator Type		Walkie		
	5	Load Capacity	Max	lb (kg)	2500 (1135)	3000** (1361**)
	6	Load Center		in (mm)	24 (600)	24 (600)
	7	Wheelbase		in (mm)	47 (1206)	50 (1280)
Tires	8	Weight	Less Battery	lb (kg)	1907 (865)	2072 (940)
	13	Wheel Size Front (d x w)	Vulkollan	in (mm)	9.8 x 3 (250 x 75)	
	14	Wheel Size Rear (d x w)	Vulkollan	in (mm)	3.2 x 4 (82 x 100)	3.2 x 2.3 (82 x 60)
	15	Additional Wheels	Caster Wheel (d x w)	in (mm)	5.9 x 2 (150 x 50)	
	16	Wheels (x=driven)	Front/Rear		1x, 1/2	1x, 1/4
Dimensions	17	Track Width	Front	in (mm)	23 (587)	
			Rear	in (mm)	15 (382)	
	18	Lift Height		in (mm)	130 (3300)	130 (3300)
	19	Free Lift	w/o Load Backrest	lb (kg)	6 (150)	68 (1720)
	20	Collapsed Height		in (mm)	84 (2130)	84 (2130)
	21	Extended Height*	w/o Load Backrest	in (mm)	147 (3730)	147 (3730)
	22	Load Backrest Size		in (mm)	47.3 (1202) H x 32.7 (832) W	
	23	Tiller Arm Height in Drive Position	Min/Max	in (mm)	31 (780) / 48 (1220)	
	24	Battery Comp't Floor Ht		in (mm)	3.4 (85)	
	25	Lowered Fork Height		in (mm)	3.5 (90)	
	27	Power Unit Height		in (mm)	29.75 (756)	
	28	Fork Lengths		in (mm)	42 (1067)	
	29	Fork Dimensions	Thickness	in (mm)	2 (50)	
			Width	in (mm)	7.5 (190)	
	30	Width Across Forks		in (mm)	27 (686)	
	31	Headlength		in (mm)	29 (730)	30 (753)
	32	Overall Length	at fork length 42"	in (mm)	71 (1803)	72 (1829)
	34	Overall Width		in (mm)	33.5 (850)	
35	Fork Carriage Width		in (mm)	27 (680)		
36	Ground Clearance	w/Load Below Mast	in (mm)	1.4 (35)		
		Center Wheelbase	in (mm)	1.2 (30)		
38	Turning Radius		in (mm)	55 (1400)	58 (1475)	
Performance	40	Travel Speed	w/wo Load	mph (km/h)	3.3 / 3.7 (5.3 / 6.0)	
	41	Lift Speed	w/wo Load	fpm (m/s)	31 / 51 (.16 / .26)	28 / 43 (.14 / .22)
	42	Lowering Speed	w/wo Load	fpm (m/s)	71 / 43 (.36 / .22)	71 / 43 (.36 / .22)
	43	Gradeability	w/wo Load, 30 min Rating	%	3 / 9	3 / 8
	44	Maximum Gradeability	w/wo Load, 5 min Rating	%	9 / 17	8 / 17
45	Service Brake			Electric		
Battery	46	Maximum Battery Box	L x W x H	in (mm)	8.5 x 32.5 x 24.7 (216 x 827 x 627)	
	47	Battery Voltage (Nominal Capacity 6 Hour Rating)		V/Ah	24 / 195	
	48	Type of Controller	Drive		Transistor	
	49	Battery Weight		lb (kg)	267-712 (121-323)	

* Subtract 32" (810 mm) from free lift; add 32" (810 mm) to extended height if optional 47.3" (1202 mm) high load backrest is required.

** Up to 110" (2800 mm), 2910 lb up to 130" (3300 mm)

English conversions are approximations. Metric conversions should be done to find true values.

Standard Equipment

1. Four-point suspension with centrally located handle
2. Traction speed control (MOSFET)
3. Variable traction speed forward and reverse
4. One-speed lift, two-speed lower
5. Electric brake
6. Brake override
7. Key switch
8. Horn
9. Compound drive and lift motor
10. Emergency power disconnect
11. Battery connector SB-175
12. Reversing button
13. Hour meter
14. Vulkollan tires
15. 27" x 42" fork configuration

Optional Equipment

1. Pivoting tandem load wheels 3.2" x 2.3" (WE 2300-25 only)
2. Battery compartment rollers
3. Battery discharge indicator with low battery lift interrupt and hour meter
4. Freezer corrosion conditioning, continuous -30° C / -22° F, intermittent -40° C / -40° F
5. Load backrest
6. Maintenance-free battery pack

Electrical System

24-volt electrical system incorporating:

1. Transistor "MOSFET" controller, microprocessor controlled with on-board service diagnostic capability. This transistor controller provides many benefits such as maximum energy efficiency, reduced maintenance and infinite speed control capability.

Fault Monitoring System:

- Through a fault flash code signaled by an LED, 17 detectable faults can be recognized. Using an optional hand set, faults can be displayed digitally. Controller settings are programmable. Functional tests of components are also possible. Incorporates storage register for fault history that can be interrogated by service personnel.
2. Heavy-duty drive and lift motors provide high reliability and efficiency.
 3. Electric panel with swing-out feature, allows good accessibility and serviceability to the distribution panel and all other electrical components.
 4. Emergency disconnect is easily accessible from all operating positions.
 5. Solid-state switching ensures high component reliability.
 6. Control and power circuits are fused. Distribution panel and controller are short-circuit protected.
 7. All wiring is color coded.

Hydraulic System

1. Heavy-duty compound motor and gear pump selected for optimum lift performance and low noise.
2. Control block houses proportional pressure compensated flow control valve, check valve, relief valve and direction control valve to select lower function. The proportional valve ensures smooth load handling. Single speed lift and two speed lowering is available to the operator.
3. Cylinder rods are hard-plated chrome with polyurethane seals.
4. Relief valve tuned to capacity protects all components in the hydraulic system.

Drive Unit/Brake

Heavy-duty gear box with helical spur input gear for low noise emission. Drive unit is equipped with an electro-magnetic brake, spring applied, electrically released. The brake is activated by the control handle position.

Frame/Pivoting Carriage

Frame and Articulated Truck Suspension system (ATS) are of a rugged design ensuring minimum deflections during operation. Modular pivoting carriage design ensures excellent traction, optimum truck stability and minimum steering effort in all load conditions. Easy serviceability of all components in power unit and simple adjustment to compensate for tire wear is possible. Single swing-out door design allows easy access to all components.

Mast

High visibility two- and three-stage mast design features nested I-beams and canted rollers. Lift cylinders are positioned in outer I-beam profile for best visibility through mast and clear view onto fork tips during load handling. Standard equipment includes full-free lift for two- and three-stage mast. Mast cushioning between stages ensures smooth operation. Heavy-duty mast and chain rollers are sealed and lubricated for life. Easy access to carriage rollers.

Operator Controls

The robust X10™ control handle is designed to allow for an optimum turning radius with low steer effort. All control buttons can be operated with either hand and can be accessed with minimum hand and wrist movement. The horn buttons are integrated in the hand grips. An ergonomic forward/reverse thumb wheel allows for precise maneuvering.

Depending on conditions and operator experience, maximum travel speed can be reduced via the rabbit/turtle switch. Exclusive brake override allows slow speed travel with the handle near vertical. This feature improves maneuverability in tight areas.

Battery

Removable side panels and top hinged cover allow easy access to battery, as well as battery change in three directions, either side or top lift out. Compartment rollers are fitted as an option.

Other Options

1. Audible travel alarm
2. Flashing lights

Safety considerations and dangers associated with audible travel alarms and flashing lights include:

- Multiple alarms and/or lights can cause confusion.
- Workers ignore the alarms and/or lights after day-in and day-out exposure.
- Operator may transfer the responsibility for "looking out" to the pedestrians.
- Annoys operators and pedestrians.

Dimensions and performance data given may vary due to manufacturing tolerances. Performance is based on an average size vehicle and is affected by weight, condition of truck, how it is equipped and the conditions of the operating area. Crown products and specifications are subject to change without notice.

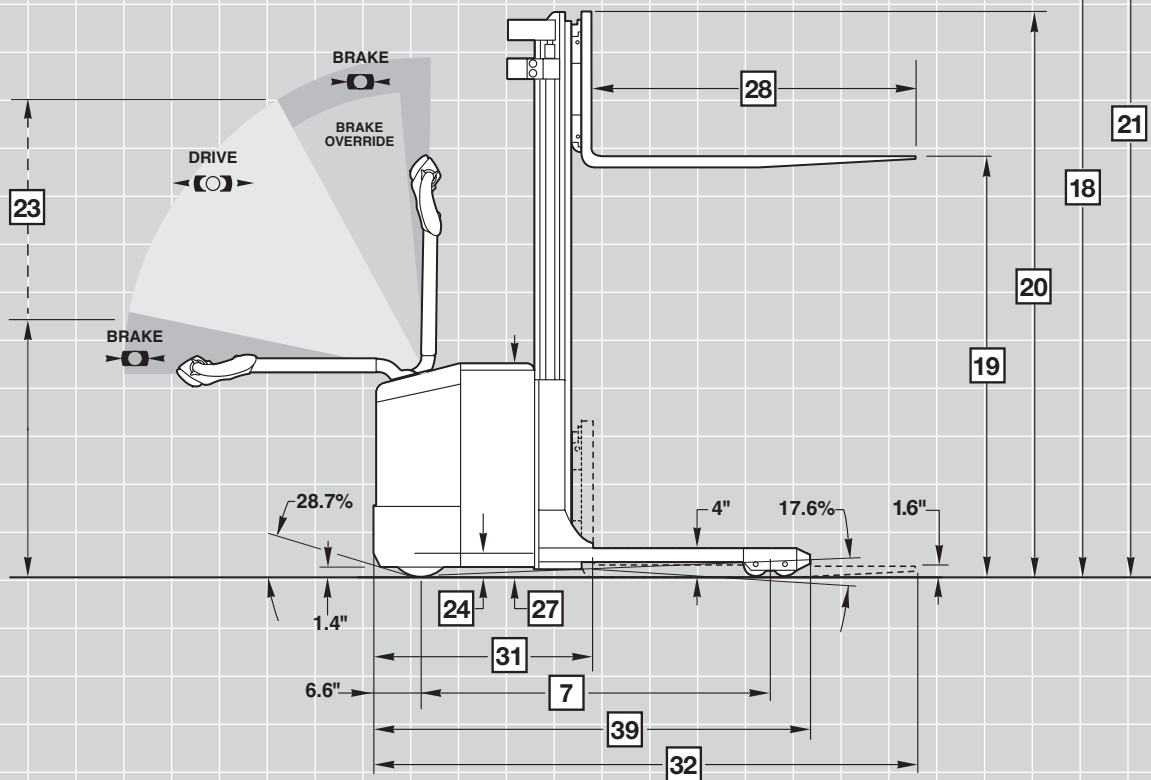
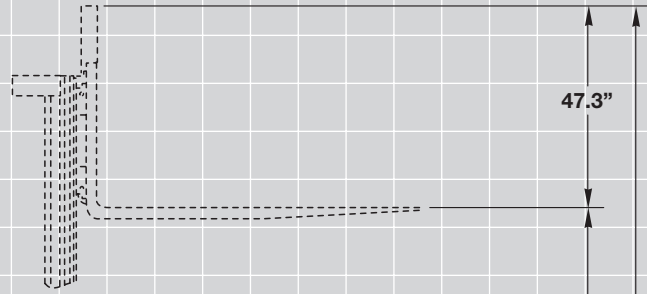
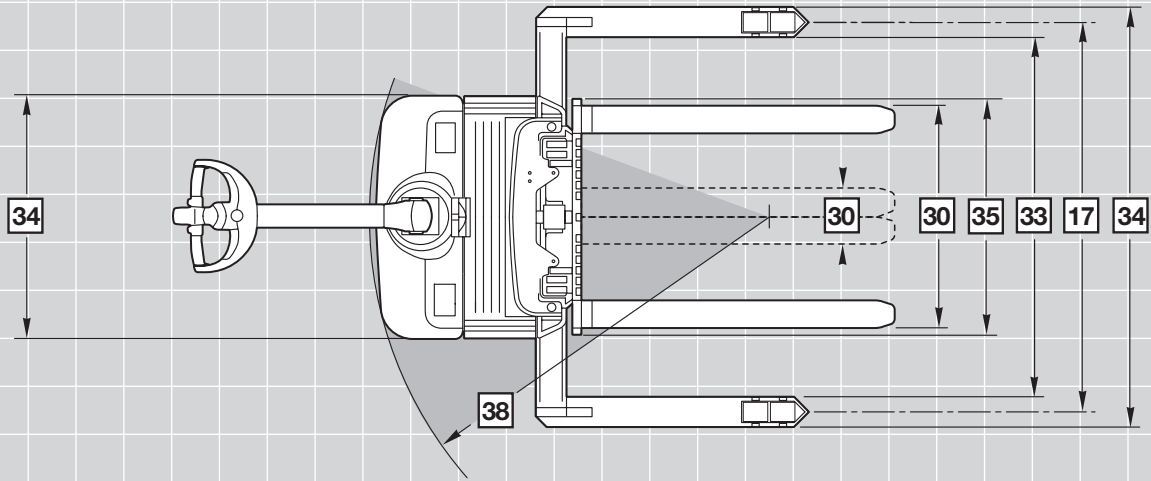

WS 2300 Series

Specifications

				Crown Equipment Corporation		
				WS 2300-40	WS 2300-40	
General Information	1	Manufacturer				
	2	Model		WS 2300-40	WS 2300-40	
		Mast Type		TL/TF	TT	
	3	Power		Electric		
	4	Operator Type		Walkie		
	5	Load Capacity	Max	lb (kg)	4000 (1815)	4000* (1815*)
	6	Load Center		in (mm)	24 (600)	24 (600)
	7	Wheelbase		in (mm)	51 (1300)	51 (1300)
8	Weight	Less Battery	lb (kg)	2072 (940)	2282 (1035)	
Tires	13	Wheel Size Front (d x w)	Vulkollan	in (mm)	9.8 x 3 (250 x 75)	
	14	Wheel Size Rear (d x w)	Vulkollan	in (mm)	3.3 x 2.8 (85 x 70)	
	15	Additional Wheels	Caster Wheel (d x w)	in (mm)	5.9 x 2 (150 x 50)	
	16	Wheels (x=driven)	Front/Rear		1x, 1/4	
	17	Track Width	Front	in (mm)	23 (587)	
		Rear	in (mm)	46, 54 (1167, 1370)		
Dimensions	18	Lift Height		in (mm)	128 (3250)	160 (4050)
	19	Free Lift **	TL	lb (kg)	4 (100)	na
		w/o Load Backrest	TF/TT**	lb (kg)	62 (1575)	51 (1305)
	20	Collapsed Height		in (mm)	84 (2130)	73 (1860)
	21	Extended Height*	w/o Load Backrest	in (mm)	151 (3825)	182 (4625)
		Outrigger Height		in (mm)	4 (100)	
	22	Lowered Fork Height		in (mm)	1.6 (40)	
	23	Tiller Arm Height in Drive Position	Min/Max	in (mm)	31 (780) / 48 (1220)	
	24	Battery Comp't Floor Ht		in (mm)	3.4 (85)	
	27	Power Unit Height		in (mm)	29.75 (756)	
	28	Fork Lengths		in (mm)	30, 36, 42, 45, 48 (760, 912, 1067, 1167, 1219)	
	29	Fork Dimensions	Thickness	in (mm)	1.6 (40)	
			Width	in (mm)	4 (100)	
	30	Width Across Forks	Adjustable Min/Max	in (mm)	10 (253) / 31.1 (790)	
	31	Headlength		in (mm)	31 (783)	32 (808)
	32	Overall Length	at fork length 42"	in (mm)	73 (1850)	74 (1875)
	33	Inside Straddle		in (mm)	42, 50 (1067, 1270)	
	34	Overall Width	Front	in (mm)	33 (850)	
		Rear	in (mm)	50, 58 (1267, 1470)		
35	Fork Carriage Width		in (mm)	32.5 (825)		
36	Ground Clearance	w/Load Below Mast	in (mm)	1.4 (35)		
37		Center Wheelbase	in (mm)	1.6 (40)		
38	Turning Radius		in (mm)	59 (1490)		
Performance	39	Length Over Outrigger		in (mm)	60 (1535)	
	40	Travel Speed	w/wo Load	mph (km/h)	3.3 / 3.7 (5.3 / 6.0)	
	41	Lift Speed	w/wo Load	fpm (m/s)	26 / 43 (.13 / .22)	
	42	Lowering Speed	w/wo Load	fpm (m/s)	71 / 39 (.36 / .20)	
	43	Gradeability	w/wo Load, 30 min Rating	%	2 / 8	
	44	Maximum Gradeability	w/wo Load, 5 min Rating	%	7 / 17	
	45	Service Brake			Electric	
Battery	46	Maximum Battery Box	L x W x H	in (mm)	8.5 x 32.5 x 24.7 (216 x 827 x 627)	
	47	Battery Voltage (Nominal Capacity 6 Hour Rating)		V/Ah	24 / 195	
	48	Type of Controller	Drive		Transistor	
	49	Battery Weight		lb (kg)	267-712 (121-323)	

* Up to 144" (3658 mm), 3548 lb up to 160" (4050 mm)

** Subtract 26" (665 mm) (WS 2300-40 TF/TT) from free lift;

Add 26" (665 mm) (WS 2300-40 TL/TF/TT) to extended height if option 47.3" (1202 mm) high load backrest is required.

English conversions are approximations. Metric conversion should be done to find true values.

Standard Equipment

1. Four-point suspension with centrally located handle
2. Traction speed control (MOSFET)
3. Variable traction speed forward and reverse
4. One-speed lift, two-speed lower
5. Electric brake
6. Brake override
7. Key switch
8. Horn
9. Compound drive and lift motor
10. Emergency power disconnect
11. Battery connector SB-175
12. Reversing button
13. Hour meter
14. Vulkollan tires

Optional Equipment

1. Battery compartment rollers
2. Battery discharge indicator with low battery lift interrupt and hour meter
3. Freezer corrosion conditioning, continuous -30° C / -22° F, intermittent -40° C / -40° F
4. Load backrest
5. Maintenance-free battery pack
6. Sideshift

Electrical System

24 volt electrical system incorporating:

1. Transistor "MOSFET" controller, microprocessor controlled with on-board service diagnostic capability. This transistor controller provides many benefits such as maximum energy efficiency, reduced maintenance and infinite speed control capability.

Fault Monitoring System

Through a fault flash code signaled by an LED, 17 detectable faults can be recognized. Using an optional hand set, faults can be displayed digitally. Controller settings are programmable. Functional tests of components are also possible. Incorporates storage register for fault history that can be interrogated by service personnel.

2. Heavy-duty drive and lift motors provide high reliability and efficiency.
3. Electric panel with swing-out feature, allows good accessibility and serviceability to the distribution panel and all other electrical components.
4. Emergency disconnect is easily accessible from all operating positions.
5. Solid-state switching ensures high component reliability.
6. Control and power circuits are fused. Distribution panel and controller are short-circuit protected.
7. All wiring is color coded.

Hydraulic System

1. Heavy-duty compound motor and gear pump selected for optimum lift performance and low noise.
2. Control block houses proportional pressure compensated flow control valve, check valve, relief valve and direction control valve to select lower function. The proportional valve ensures smooth load handling. Single speed lift and two speed lowering is available to the operator.
3. Cylinder rods are hard-plated chrome with polyurethane seals.
4. Relief valve tuned to capacity protects all components in the hydraulic system.

Drive Unit/Brake

Heavy-duty gear box with helical spur input gear for low noise emission. Drive unit is equipped with an electro-magnetic brake, spring applied, electrically released. The brake is activated by the control handle position.

Frame/Pivoting Carriage

Frame and Articulated Truck Suspension system (ATS) are of a rugged design ensuring minimum deflections during operation. Modular pivoting carriage design ensures excellent traction, optimum truck stability and minimum steering effort in all load conditions. Easy serviceability of all components in power unit and simple adjustment to compensate for tire wear is possible. Single swing-out door design allows easy access to all components.

Mast

High visibility two- and three-stage mast design features nested I-beams and canted rollers. Lift cylinders are positioned in outer I-beam profile for best visibility through mast and clear view onto fork tips during load handling. Standard equipment includes full-free lift for two- and three-stage mast. Mast cushioning between stages ensures smooth operation. Heavy-duty mast and chain rollers are sealed and lubricated for life. Easy access to carriage rollers.

Fork Carriage

WS 2300 Series features a standard 32" wide ITA Class II fork carriage. Forks are adjustable from 10" to 31". Standard fork lengths are 30", 36", 42" 45" and 48".

Operator Controls

The robust X10™ control handle is designed to allow for an optimum turning radius with low steer effort. All control buttons can be operated with either hand and can be accessed with minimum hand and wrist movement. The horn buttons are integrated in the hand grips. An ergonomic forward/reverse thumb wheel allows for precise maneuvering. Depending on conditions and operator experience, maximum travel speed can be reduced via the rabbit/turtle switch. Exclusive brake override allows slow speed travel with the handle near vertical. This feature improves maneuverability in tight areas.

Battery

Removable side panels and top hinged cover allow easy access to battery, as well as battery change in three directions, either side or top lift out. Compartment rollers are fitted as an option.

Other Options

1. Audible travel alarm
2. Flashing lights

Safety considerations and dangers associated with audible travel alarms and flashing lights include:

- Multiple alarms and/or lights can cause confusion.
- Workers ignore the alarms and/or lights after day-in and day-out exposure.
- Operator may transfer the responsibility for "looking out" to the pedestrians.
- Annoys operators and pedestrians.

Dimensions and performance data given may vary due to manufacturing tolerances. Performance is based on an average size vehicle and is affected by weight, condition of truck, how it is equipped and the conditions of the operating area. Crown products and specifications are subject to change without notice.



Crown Equipment Corporation
New Bremen, Ohio 45869 USA
Tel 419-629-2311
Fax 419-629-3796
crown.com

Because Crown is continually improving its products,
specifications are subject to change without notice.

Crown, the Momentum symbol and The X10 Handle are
trademarks of Crown Equipment Corporation.

Copyright 2004 Crown Equipment Corporation
SF14404 5/04
Printed in U.S.A.